



Damage Control Plotting Drill #1

Drill # 1

1 Time: 0900; From OSL to Rep 3

smoke reported, black, compartment 2-328-2-L

2 Time: 0905; From OSL to Rep 3

Class "A" fire, compartment 2-328-0-Q

3 Time: 0911; From OSL to Rep 3

Request fire boundaries,

Primary 328, 368

Secondary 292, 418

Drill # 1

4 Time: 0913; From OSL to Rep 3

Request magazine sprinkler system be manned,
compartment 2-328-0-Q

5 Time: 0917; From OSL to Rep 3

Electrical power engaged, compartment 2-328-0-Q

6 Time: 0918; From Rep 3 to OSL

Fire boundaries ordered,

Primary 328, 368

Secondary 292, 418

Drill # 1

7 Time: 0920; From OSL to Rep 3

Shoring required at scene, compartment 2-368-01-L,

frame 368, Remarks-QAWTD 2-386-2 (I type)

8 Time: 0924; From OSL to Rep 3

Compartment Demolished, 2-368-1-A

9 Time: 0928; From OSL to Rep 3

Fire boundaries set, compartment 2-328-0-Q

Primary 328, 368

Secondary 292,418

Drill # 1

10 Time: 0931; From OSL to Rep 3

Class "A" fire engaged, compartment 2-328-0-Q

11 Time: 0940; From OSL to Rep 3

6 inch Hole reported, compartment 2-328-2-L,
at frame 365, center of hole is 4 foot off the
deck,
port side

12 Time: 0951; From OSL to Rep 3

Class "A" fire out (No Casualty), compartment
2-328-0-Q

Drill # 1

13 Time: 0956; From OSL to Rep 3

Ruptured firemain reported, compartment 2-368-01-L, frame 388, on the centerline overhead

14 Time: 1001; From OSL to Rep 3

Shoring in progress, (Steel) compartment 2-368-01-L,

Remarks: QAWTD 2-386-2

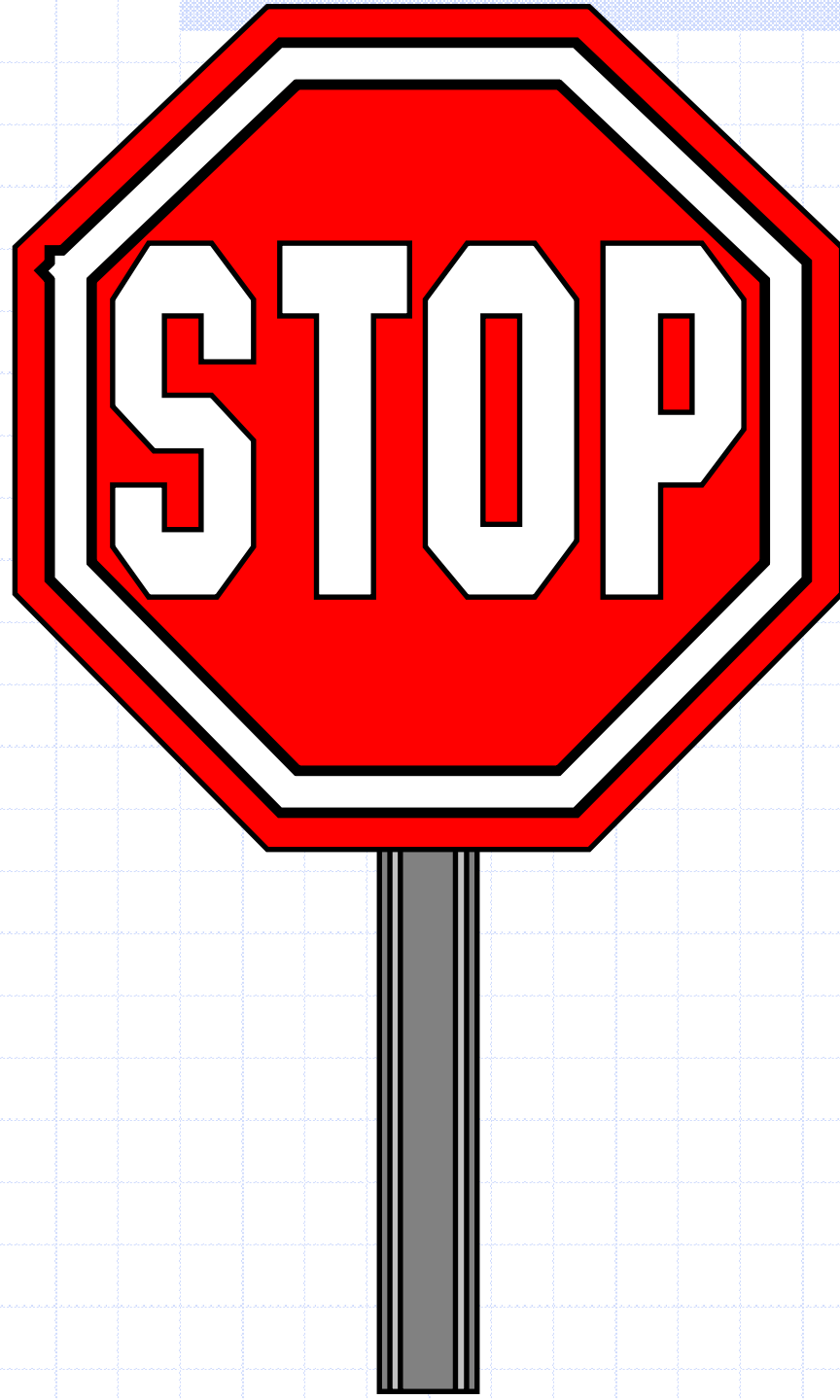

Drill # 1

15 Time: 1012; From OSL to Rep 3

Ruptured firemain isolated, COV 2-366-2, compartment 2-328-2-L, at frame 388

16 Time: 1018; From OSL to Rep 3

Compartment cleared, 2-368-1-A.

17 Time: 1023; From OSL to Rep 3

Shoring complete, (I Type)No structure damage

Remarks: QAWTD 2-386-2

Drill #1

18 Time: 1033; From OSL to Rep 3

6 inch hole, plugging in progress, compartment
2-328-2-L

Drill # 1

19 Time: 1040; From OSL to Rep 3

Smoke cleared, black, compartment 2-328-2-L,

Ram Fan (2000 CFM, 125 PSI).

Drill # 1

20 **Time: 1110; From OSL to Rep 3**

No apparent electrical damage, compartment 2-328-0-Q

Drill # 1

21 Time: 1123; From OSL to Rep 3

No apparent damage surrounding areas,
compartment

2-328-0-Q

LAST MESSAGE!!

S

Black

Time: **0900**

1

From

F/M-INV-SL

To

DCRS-2

DCRS-3

DCRS-5

DCC

X

X

COMP.# NAME

2-328-2-L

Frame

Remarks:

Message

1

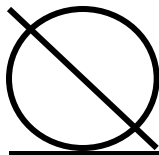
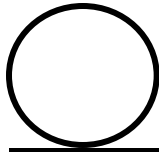

OVHD/FWD

PORT

STBD

DECK/AFT

BOUNDARIES

FB- SB- FLB- CB

S

P

P

S

Time: **0905**

2

A

From
X

F/M-INV-SL
DCRS-2
DCRS-3
DCRS-5
DCC

To

X

COMP.# NAME

2-328-0-Q

Frame

Remarks:

Message
2

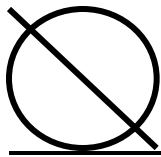
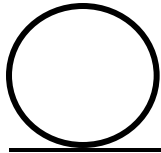

OVHD/FWD

PORT

STBD

DECK/AFT

BOUNDARIES

FB- SB- FLB- CB

S

P

P

S

Time: 0911

#3

FB

From
X

F/M-INV-SL
DCRS-2
DCRS-3
DCRS-5
DCC

To

X

COMP# NAME

Frame

Request fire boundaries

Remarks:

Pri 328, 368 sec 292, 418

OVHD/FWD

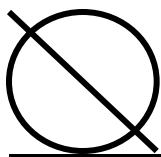

PORT

STBD

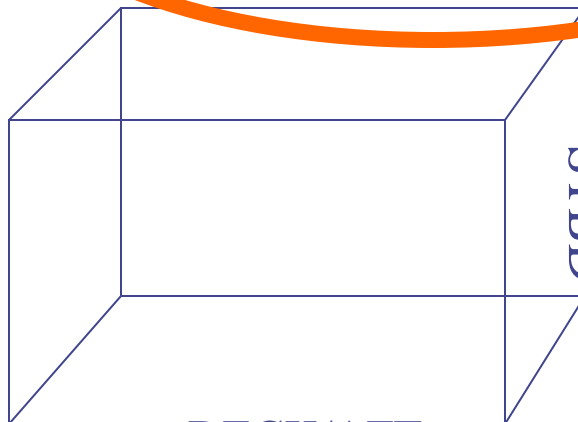

DECK/AFT

BOUNDARIES

FB- SB- FLB- CB

S

P

P

S

Message
#3

Time: **0913**

#4

From
X

F/M-INV-SL
DCRS-2
DCRS-3
DCRS-5
DCC

To

X

COMP.# NAME

Frame

Remarks:

**Request Mag Sprinkler sys
manned 2-328-0-Q.**

Message
#4

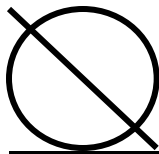
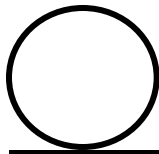

OVHD/FWD

PORT

STBD

DECK/AFT

BOUNDARIES

FB- SB- FLB- CB

S

P

P

S

Time: **0917**

#5

From

X

F/M-INV-SL

To

DCRS-2

DCRS-3

DCRS-5

DCC

X

COMP.# NAME

2-328-0-Q

Frame

Remarks:

Message
#5

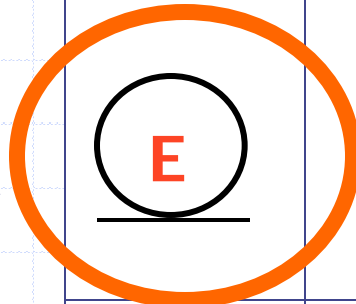

OVHD/FWD

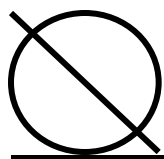

PORT

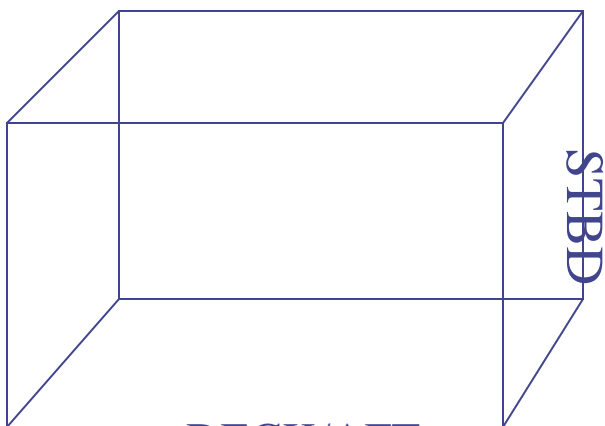

DECK/AFT

BOUNDARIES

FB- SB- FLB- CB

S

P

P

S

Time:0918

#6

FB

From

F/M-INV-SL

To

X

DCRS-2

DCRS-3

DCRS-5

DCC

X

COMP.# NAME

Frame

Remarks:

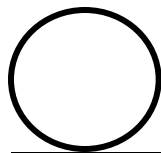

Message
#6

OVHD/FWD

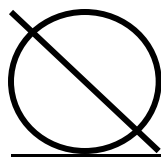

PORT

STBD

DECK/AFT

BOUNDARIES

FB- SB- FLB- CB

S

P

P

S

292

328

368

418

Time: 0920

#7

STR
I-TYPE

From
X

F/M-INV-SL
DCRS-2
DCRS-3
DCRS-5
DCC

To

X

COMP.# NAME

Frame

Remarks:

QAWTD 2-386-2

Message
#7

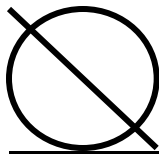
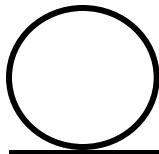

OVHD/FWD

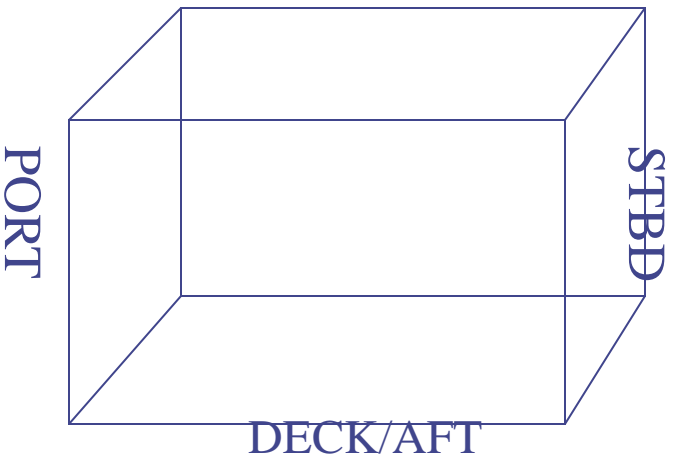

BOUNDARIES

FB- SB- FLB- CB

S

P

P

S

Time: 0924

#8

C/D

From
X

F/M-INV-SL

To

DCRS-2

DCRS-3

DCRS-5

DCC

X

COMP.# NAME

2-368-1-A

Frame

Remarks:

Message
#8

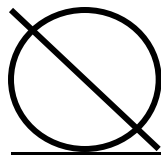
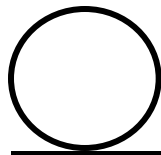

OVHD/FWD

PORT

STBD

DECK/AFT

BOUNDARIES

FB- SB- FLB- CB

S

P

P

S

Time: **0928**

#9

From
X

F/M-INV-SL
DCRS-2
DCRS-3
DCRS-5
DCC

To

X

COMP.# NAME

2-328-0-Q

Frame

Remarks:

Message
#9

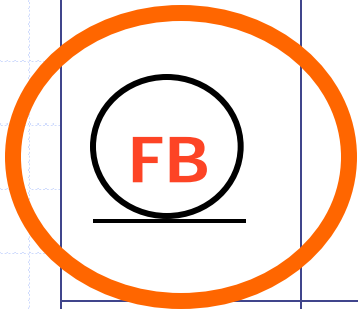

OVHD/FWD

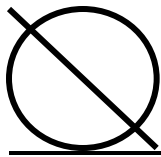

PORT

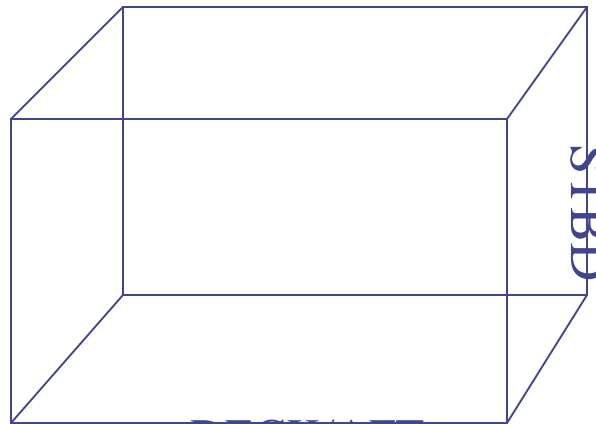

DECK/AFT

BOUNDARIES

FB- SB- FLB- CB

S

292

P

328

P

368

S

418

Time: 0931

#10

From
X

F/M-INV-SL
DCRS-2
DCRS-3
DCRS-5
DCC

To

X

COMP.# NAME

2-328-0-Q

Frame

Remarks:

Message
#10

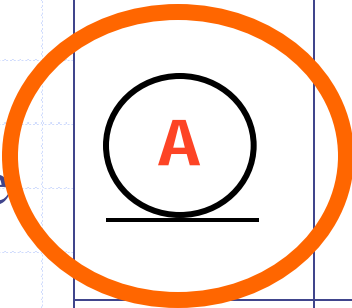

OVHD/FWD

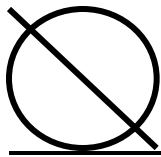

PORT

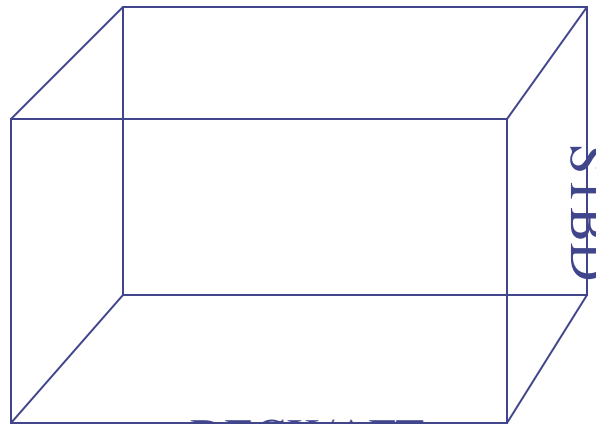

DECK/AFT

BOUNDARIES

FB- SB- FLB- CB

S

P

P

S

Time: 0940

#11

H
6" fr 365
4' off deck

From
X

F/M-INV-SL
DCRS-2
DCRS-3
DCRS-5
DCC

To

X

COMP.# NAME

2-328-2-L

Frame

Remarks:

Message
#11

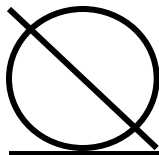
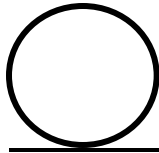

OVHD/FWD

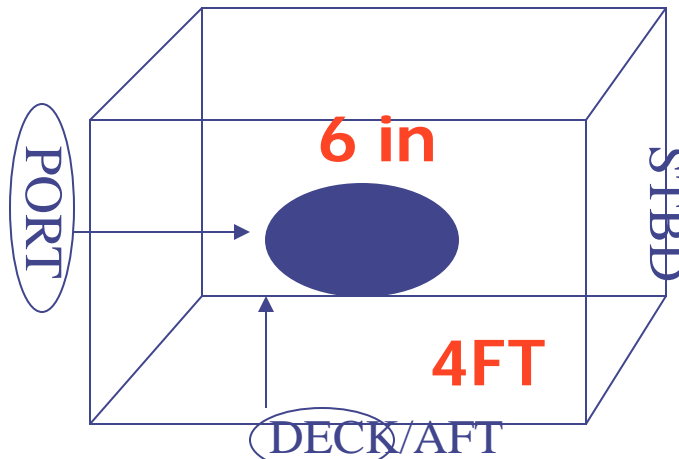

DECK/AFT

BOUNDARIES

FB- SB- FLB- CB

S

P

P

S

Time:0951

#12

From
X

F/M-INV-SL
DCRS-2
DCRS-3
DCRS-5
DCC

To

X

COMP.# NAME

2-328-0-Q

Frame

Remarks:

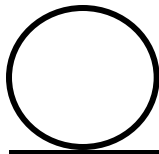

Message
#12

OVHD/FWD

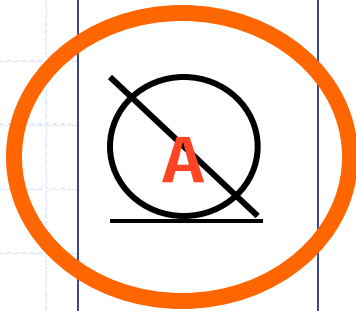

PORT

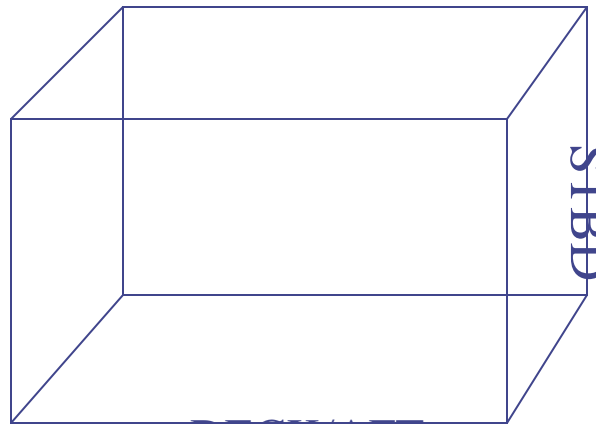

DECK/AFT

BOUNDARIES

FB- SB- FLB- CB

S

P

P

S

Time: 0956

#13

R
FM
FR 388

From
X

F/M-INV-SL
DCRS-2
DCRS-3
DCRS-5
DCC

To

X

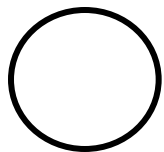

COMP.# NAME

2-368-01-L

Frame

Remarks:

Message
#13

OVHD/FWD

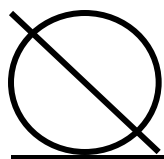

PORT

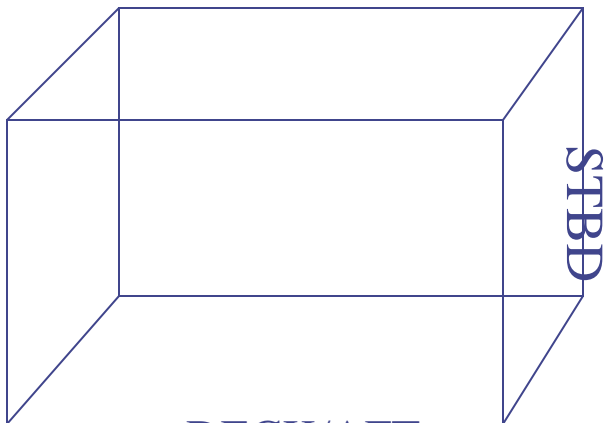

DECK/AFT

BOUNDARIES

FB- SB- FLB- CB

S

P

P

S

Time: 1001

#14

From
X

F/M-INV-SL
DCRS-2
DCRS-3
DCRS-5
DCC

To

X

COMP.# NAME

2-368-01-L

Frame

Remarks:

QAWTD 2-386-2

Message
#14

STR

I-TYPE

OVHD/FWD

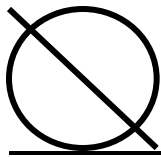

PORT

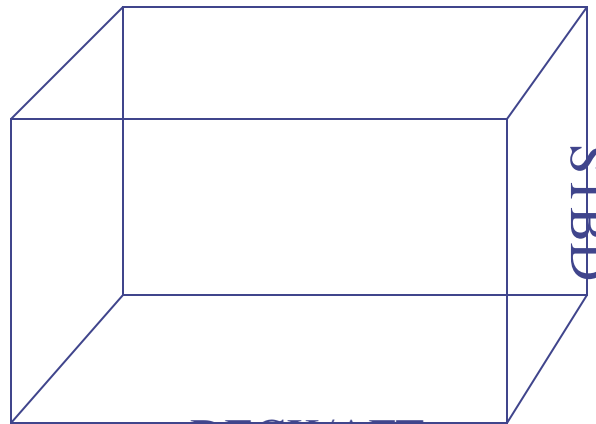

DECK/AFT

BOUNDARIES

FB- SB- FLB- CB

S

P

P

S

Time: 1012

#15

From
X

F/M-INV-SL
DCRS-2
DCRS-3
DCRS-5
DCC

To

X

COMP.# NAME

2-366-2-L

Frame

Remarks: **COV 2-366-2**

Message
#15

R

FM

FR 388

OVHD/FWD

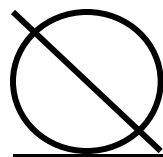

PORT

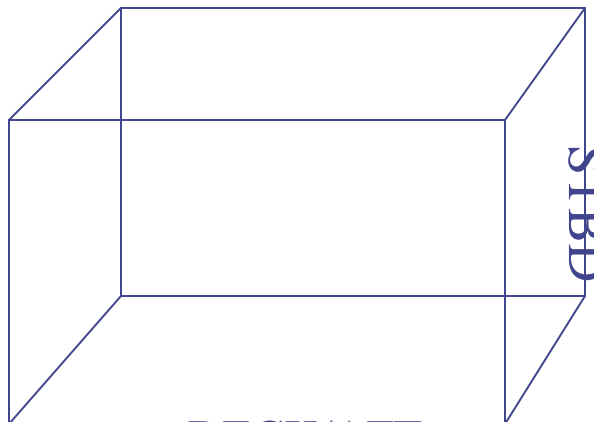

DECK/AFT

BOUNDARIES

FB- SB- FLB- CB

S

P

P

S

Time: 1018

#16

From
X

F/M-INV-SL

To

DCRS-2

DCRS-3

DCRS-5

DCC

X

COMP.# NAME

2-368-1-A

Frame

Remarks:

C/D

Message
#16

OVHD/FWD

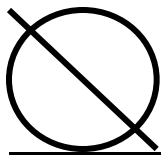

PORT

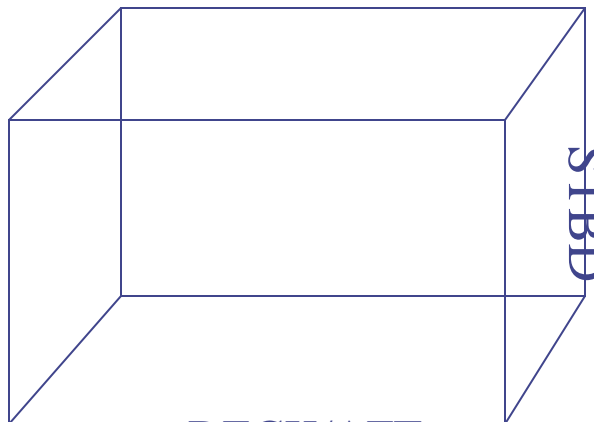

DECK/AFT

BOUNDARIES

FB- SB- FLB- CB

S

P

P

S

Time: 1023

#17

From
X

F/M-INV-SL
DCRS-2
DCRS-3
DCRS-5
DCC

To

X

COMP.# NAME

Frame

Remarks: QAWTD 2-386-2

OVHD/FWD

~~STR~~

I-TYPE

PORT

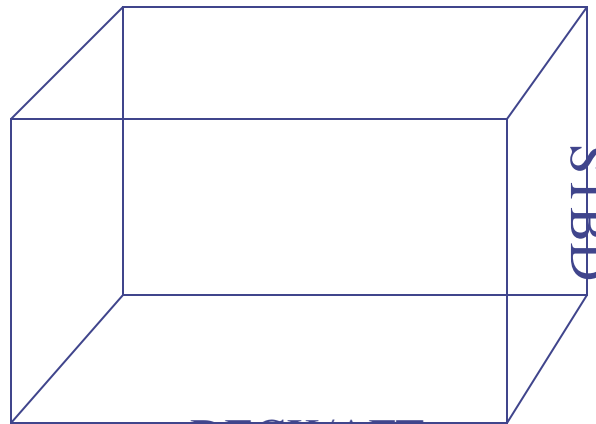

DECK/AFT

BOUNDARIES

FB- SB- FLB- CB

S

P

P

S

Message
#17

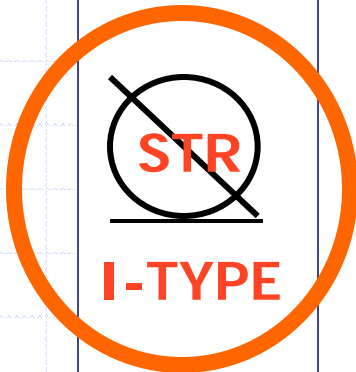
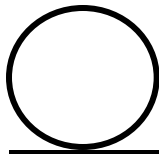

Time: 1033

#18

From
X

F/M-INV-SL
DCRS-2
DCRS-3
DCRS-5
DCC

To

X

COMP.# NAME

Frame

Remarks:

Message
#18

H
6" fr 365
4' off deck

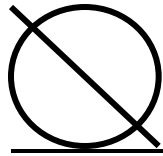

OVHD/FWD

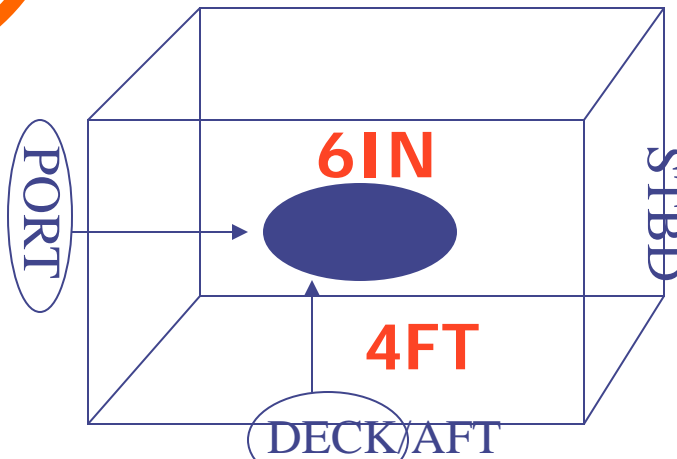

BOUNDARIES

FB- SB- FLB- CB

S

P

P

S

Time: 1040

#19

From
X

F/M-INV-SL
DCRS-2
DCRS-3
DCRS-5
DCC

To

X

COMP.# NAME

2-368-01-L

Frame

Remarks: **Ram Fan (2000 CFM, 125 PSI)**

Message
#19

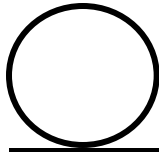

OVHD/FWD

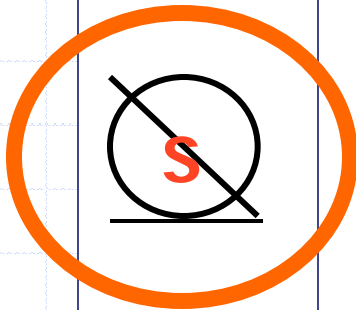

PORT

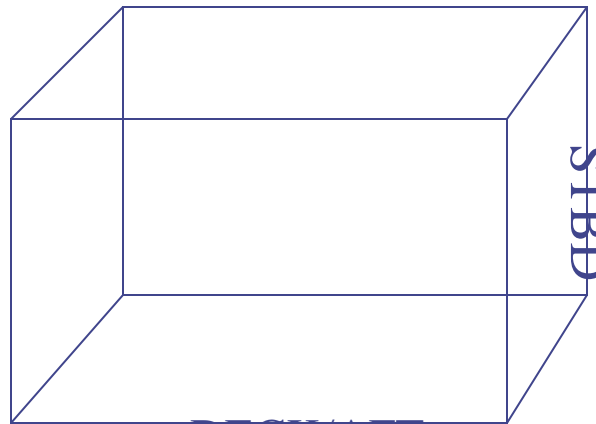

DECK/AFT

BOUNDARIES

FB- SB- FLB- CB

S

P

P

S

NAED

Time: **1110**

#20

From

X

F/M-INV-SL

To

DCRS-2

DCRS-3

DCRS-5

DCC

X

COMP.# NAME

2-328-2-L

Frame

Remarks:

Message

#20

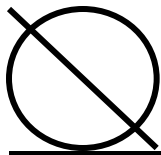
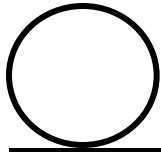

OVHD/FWD

PORT

STBD

DECK/AFT

BOUNDARIES

FB- SB- FLB- CB

S

P

P

S

Time: 1123

#21

NADS

From
X

F/M-INV-SL

To

DCRS-2

DCRS-3

DCRS-5

DCC

X

COMP.# NAME

Frame

Remarks:

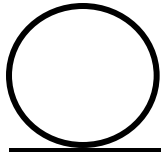

Message
#21

OVHD/FWD

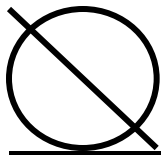

PORT

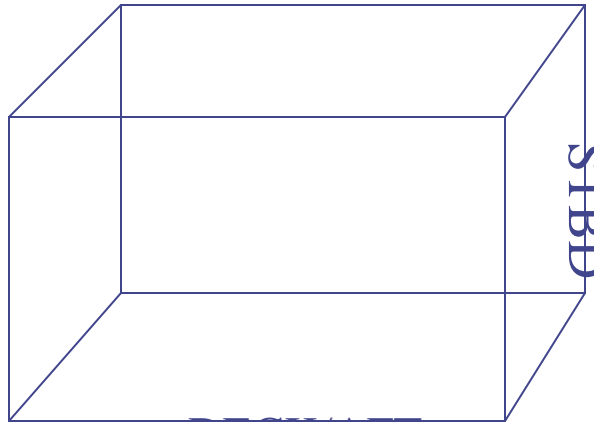

DECK/AFT

BOUNDARIES

FB- SB- FLB- CB

S

P

P

S