

NOTE: 1. TRACK SYSTEM MUST BE EQUAL TO THOSE AVAILABLE FROM:  
PERFORMANCE ADVANTAGE COMPANY (PAC)  
P.O. BOX 306  
LANCASTER, NEW YORK 14086  
(716) 683-7413

**DAMAGE CONTROL EQUIPMENT STOWAGE SKETCH #098**  
**CBR-D IPE STOWAGE RACK**  
**TRACK SYSTEM – VERTICAL MOUNT (DECK TO OVERHEAD)**

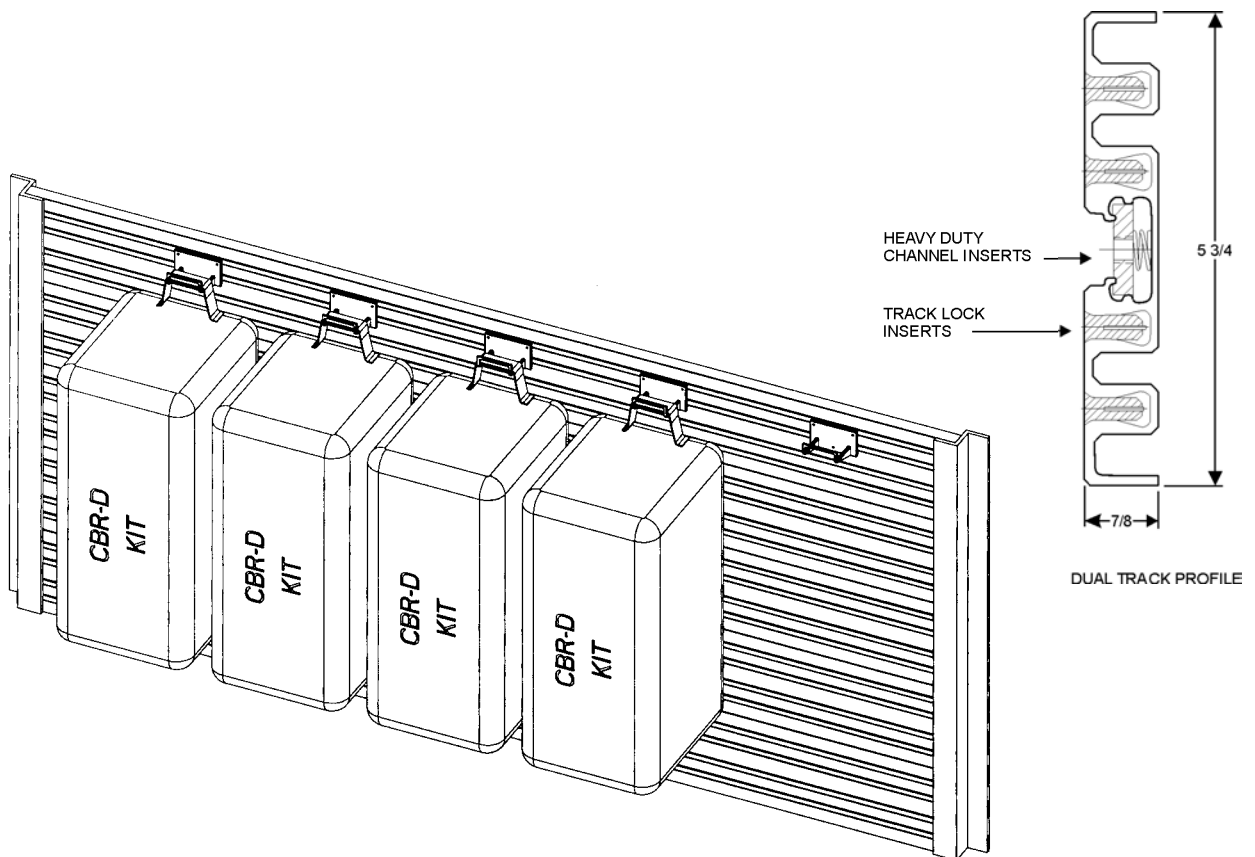

NOTE: 1. TRACK SYSTEM MUST BE EQUAL TO THOSE AVAILABLE FROM:  
PERFORMANCE ADVANTAGE COMPANY (PAC)  
P.O. BOX 306  
LANCASTER, NEW YORK 14086  
(716) 683-7413

**DAMAGE CONTROL EQUIPMENT STOWAGE SKETCH #099**  
**CBR-D IPE STOWAGE RACK**  
**TRACK SYSTEM – HORIZONTAL MOUNT (BULKHEAD)**

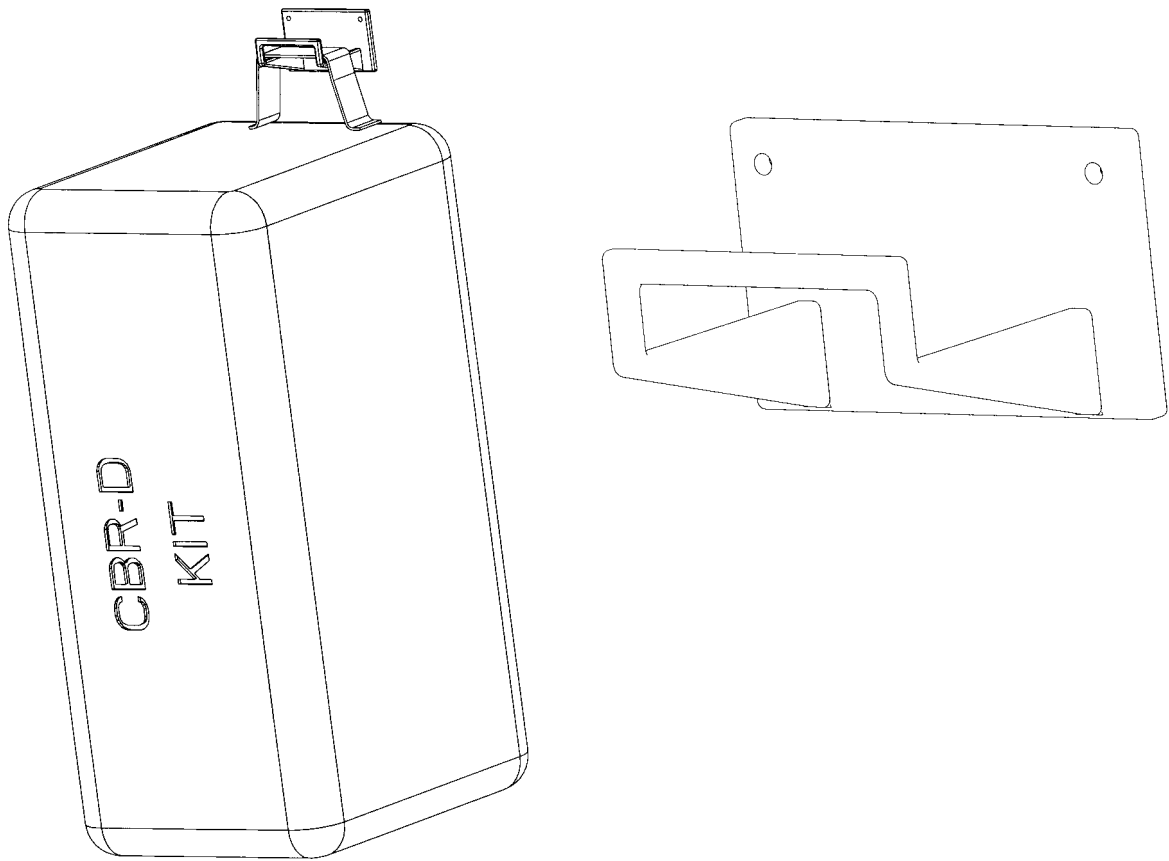

NOTE: 1. HOOK MUST BE EQUAL TO THOSE AVAILABLE FROM:  
PERFORMANCE ADVANTAGE COMPANY (PAC)  
P.O. BOX 306  
LANCASTER, NEW YORK 14086  
(716) 683-7413

**DAMAGE CONTROL EQUIPMENT STOWAGE SKETCH #100**  
**CBR-D IPE STOWAGE HOOK**

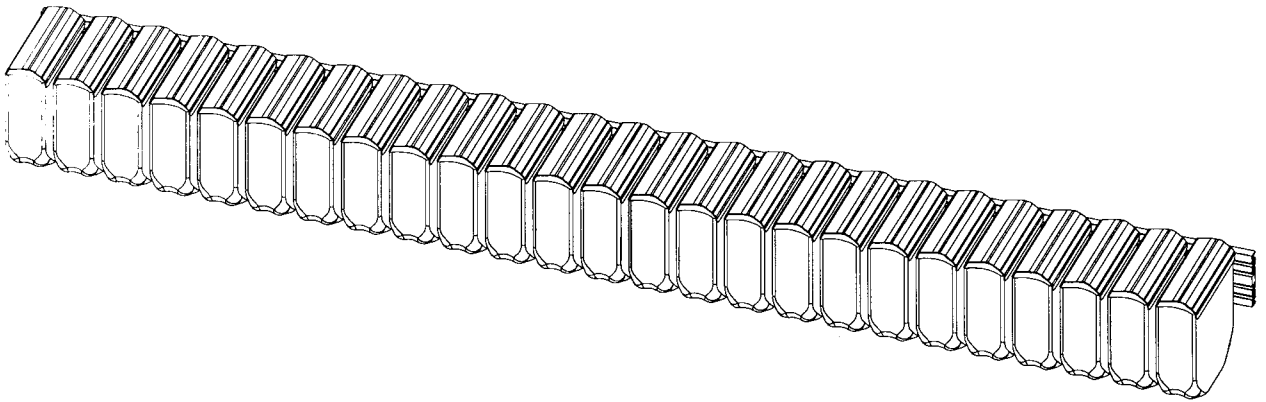

- NOTE: 1. TRACK SYSTEM MUST BE EQUAL TO THOSE AVAILABLE FROM:  
PERFORMANCE ADVANTAGE COMPANY (PAC)  
P.O. BOX 306  
LANCASTER, NEW YORK 14086  
(716) 683-7413
2. SEE SKETCH #099 FOR TRACK DIMENSIONS.

**DAMAGE CONTROL EQUIPMENT STOWAGE SKETCH #101**  
**MCU-2P STOWAGE RACK**

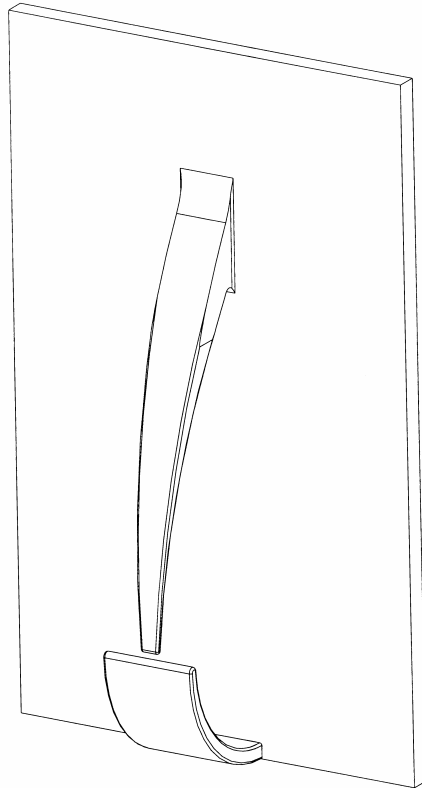

NOTE: 1. HOOK MUST BE EQUAL TO THOSE AVAILABLE FROM:  
PERFORMANCE ADVANTAGE COMPANY (PAC)  
P.O. BOX 306  
LANCASTER, NEW YORK 14086  
(716) 683-7413

**DAMAGE CONTROL EQUIPMENT STOWAGE SKETCH #102**  
**MCU-2P STOWAGE HOOK**