

**FIREFIGHTING /  
ACCESS EQUIPMENT  
KIT**

**AEL Range: 2-880044252 to 4253**

A laminated inventory list should be provided with this kit.

# FIREFIGHTING/ACCESS EQUIPMENT KIT

Quantity  
Required

KIT - FIRE FIGHTING/ACCESS  
EQUIPMENT-DC

1H 0000-LL-CQA-2454

This kit identifies all equipment used for the function of providing access to fire areas. Individual items are listed on AEL #2-880044252 and in alphabetical order in this guide.

**AFFF FOAM CONCENTRATE -**

NSN 4210-01-056-8343

WT. 45.0 lbs

VOL. 1,983.8 in.<sup>3</sup>

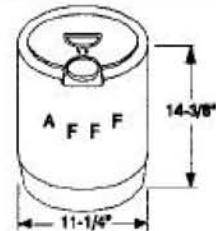

4

Helpful Hints: Can be stowed in rack in passageway.

Actual Inventory:

**APPLICATOR NOZZLE - 4 FEET**

NSN 4210-00-372-0864

WT. 5.0 lbs.

VOL. 924.0 in.<sup>3</sup>

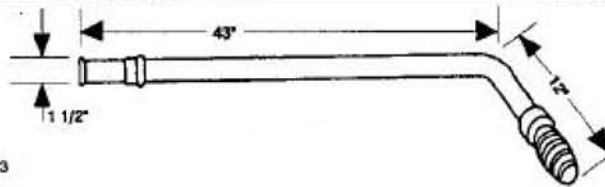

1

Helpful Hints:

Actual Inventory:

**AX-PICK HEAD - CARBON STEEL  
TYPE II 5" CUTTING EDGE**

NSN 4210-00-142-4949

WT. 8.4 lbs.

VOL. 545.5 in.<sup>3</sup>

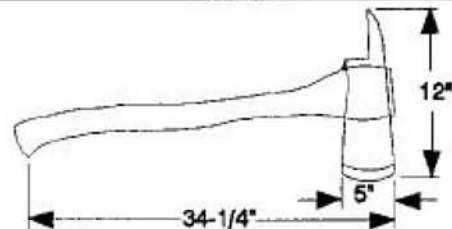

1

Helpful Hints: Recommend providing protective cover for ax blade.

Actual Inventory:

# FIREFIGHTING/ACCESS EQUIPMENT KIT

Quantity  
Required

**BAG, LINEMAN TOOL -**

**NSN 5140-00-288-7763**

**WT. 3.1 lbs**

**VOL. 594.0 in<sup>3</sup>**

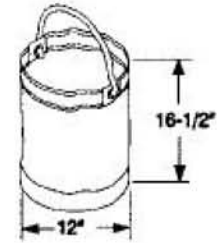

1

Helpful Hints:

New inventory item. Utilize existing bag. Not to exceed 18" in dia/width. Order as replacement. Replace with color-coded photo-luminescent marked bag, GGG-B-50, as NAVSEA funds are available.

Actual Inventory:

**BAR CHISEL - 36" PRY BAR**

**NSN 5110-00-240-6031**

**WT. 7.0 lbs.**

**VOL. 40.8 in.<sup>3</sup>**

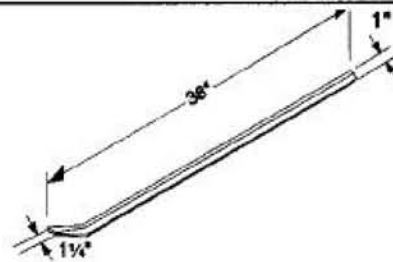

1

Helpful Hints: Replacement item. Utilize 60" pinch bar if onboard.

Actual Inventory:

**CUTTER - BOLT**

24" LONG 3/8" CAPACITY

CUT WROUGHT IRON, ANNEALED SOFT STEEL  
BOLTS, RIVETS, AND COLD DRAWN SCREW STOCK.

**NSN 5110-00-598-9156**

**WT. 7.0 lbs.**

**VOL. 171.9 in.<sup>3</sup>**

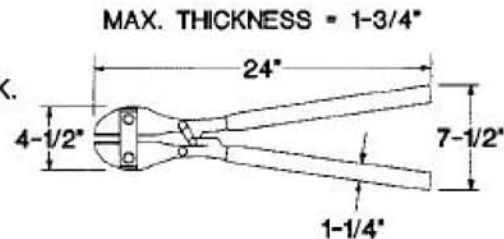

1

Helpful Hints:

Actual Inventory:

# FIREFIGHTING/ACCESS EQUIPMENT KIT

Quantity  
Required

**HAMMER - BLACKSMITH SLEDGE**  
12 LB.  
CROSSPEEN HEAD  
34 IN. HANDLE-HICKORY

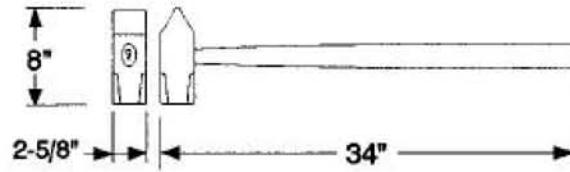

1

**NSN 5120-00-224-4130**

**WT.** 14.0 lbs.

**VOL.** 678.1 in.<sup>3</sup>

Helpful Hints:

Actual Inventory:

**HOSE - 1-1/2" x 50 FT.**  
NON-METALLIC

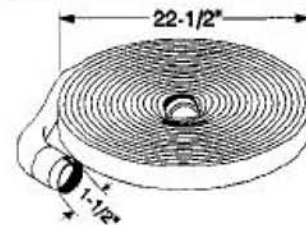

1

**NSN 4210-01-131-0249**

**WT.** 25.0 lbs.

**VOL.** 1,772.0 in.<sup>3</sup>

Helpful Hints: Ships are to phase replace the 1 1/2" hose with the 1 3/4" firehose (NSN 4210-01-143-1404)

Actual Inventory:

**INLINE AFFE EDUCTOR -**

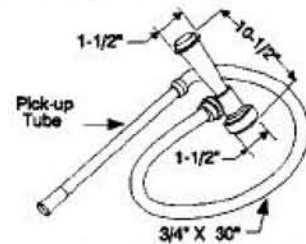

1

**NSN 4210-01-112-3081**

**WT.** 7.0 lbs.

**VOL.** 393.7 in.<sup>3</sup>

Helpful Hints: Can be used with either 1 1/2" or 1 3/4" firehose.

Actual Inventory:

# FIREFIGHTING/ACCESS EQUIPMENT KIT

Quantity  
Required

## LADDER - SCALING

1HS0000-LL-CJ7-5890

WT. 22.0 lbs.

VOL. 7320.0 in.<sup>3</sup>

Helpful Hints:

**DELETE**

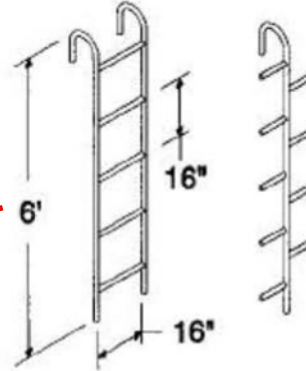

1

To be manufactured by ship's force. NAVSEA dwg #804-5959241. Gen note: Coat entire assembly with plastisol IAW MIL-P-20689 to improve grip and to provide electrical insulation. Utilize ladder onboard. Replace with wide step ladder.

Actual Inventory:

## NOZZLE - FIRE HOSE WATER 3 POSITION APN 1-1/2"

NSN 4210-00-392-2943

WT. 10.0 lbs.

VOL. 210.0 in.<sup>3</sup>

Helpful Hints: Can be used with either 1 1/2" or 1 3/4" firehose.

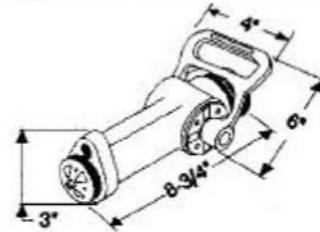

1

Actual Inventory:

## NOZZLE - VARIABLE FOAM 2-1/2" TYPE I

NSN 4210-00-465-1904

WT. 13.0 lbs.

VOL. 258.0 in.<sup>3</sup>

Helpful Hints:

**DELETE**

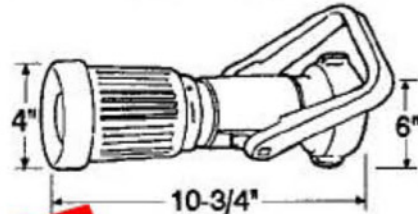

1

Actual Inventory:

# FIREFIGHTING/ACCESS EQUIPMENT KIT

Quantity  
Required

**NOZZLE - VARIABLE (BRASS)**  
1-1/2"

NSN 4210-00-465-1906

WT. 9.0 lbs. VOL. 301.8in<sup>3</sup>

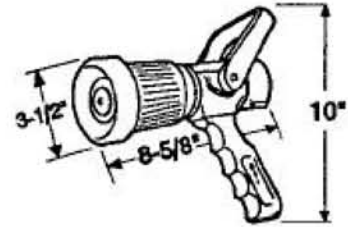

2

Helpful Hints: Can be used with either 1 1/2" or 1 3/4" hose.

Actual Inventory:

**RAKE - OVERHAUL**

NSN 4210-00-203-3512

WT. 8.0 lbs. VOL. 35.0 in<sup>3</sup>

Helpful Hints: Replaces overhaul rake fabricated IAW Dwg No. 804-5959242. NAVSEA will provide as funds become available.

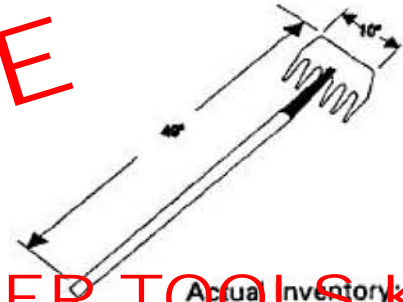

1

Actual Inventory:

**SHOVEL - SCOOP**

NSN 5120-00-188-8446

WT. 8.5 lbs. VOL. 1,144 in<sup>3</sup>

Helpful Hints: NAVSEA will provide as funds become available.

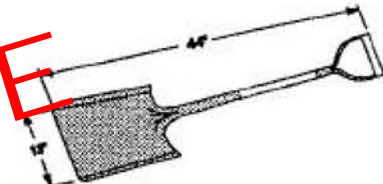

1

Actual Inventory:

**WEDGE - JNT BRKG, STEEL**  
SIZE 4  
HARDENED STEEL  
3/4" x 1-1/2" x 4"

NSN 5120-00-224-9486

WT. 2.0 lbs. VOL. 2.2 in<sup>3</sup>

Helpful Hints: (1" x 1-1/2" butt)

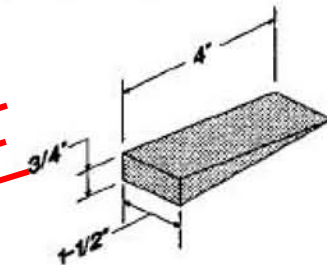

4

Actual Inventory:

# FIREFIGHTING/ACCESS EQUIPMENT KIT

Quantity  
Required

**WEDGE - JNT BRKG, STEEL**  
SIZE 5  
HARDENED STEEL  
2" x 2" x 5"

NSN 5120-00-224-9487

WT. 5.0 lbs.

VOL. 10.0 in.<sup>3</sup>

**DELETE**

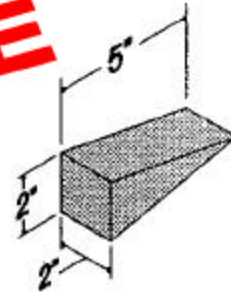

4

Helpful Hints:

Actual Inventory:

**WRENCH - SPANNER**  
ADJUSTABLE HOOK WITH FIXED PIVOT  
RANGE FROM 2" TO 4-3/4"

NSN 5120-00-277-9076

WT. 2.0 lbs.

VOL. 6.7 in.<sup>3</sup>



2

Helpful Hints:

**DELETE**

Actual Inventory:

**WRENCH - SPANNER**  
3/4" TO 2"

NSN 5120-00-288-8746

WT. 1.3 lbs

VOL. 3.0 in.<sup>3</sup>

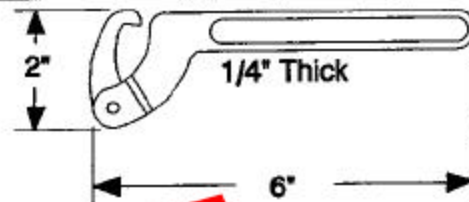

2

Helpful Hints:

**DELETE**

Actual Inventory: